

PHILIPS

dynalite 

DBC905

Ecolinx 9 x 5A Structured Wiring HF Ballast Controller
Installation Manual



contents

Warning.....	2	Typical system / Equipment Layout.	9
Features.....	2	Trouble shooting.....	10
Important Safeguards.....	2	Specifications.....	10
Loading.....	3		
Installation & Wiring.....	4		
Network & Input Removable Terminal Conectors	8		



Warning

- TO REDUCE THE RISK OF FIRE OR ELECTRIC SHOCK, DO NOT EXPOSE THIS DEVICE TO RAIN OR MOISTURE.
- DO NOT ENERGISE UNLESS THE UNIT IS FULLY ASSEMBLED.
- THIS DEVICE MUST BE EARTHED.
- INSTALLATION, PROGRAMMING AND MAINTENANCE MUST BE CARRIED OUT BY QUALIFIED PERSONNEL

important safeguards

Warning – This is a class A product. In a domestic environment this product may cause radio interference, in which case the user may be required to take adequate measures.

Read Instructions – We recommend that you read this instruction manual prior to commencement of installation. Retain instructions and give the end user the Preset Programming Guide (pages 7-8) if applicable.

Troubleshooting - If problems are encountered, check the troubleshooting section on page 10.

Special Programming – Once powered and terminated correctly this device will only operate in basic mode. A new Dynalite panel will turn on all lighting channels from button 1 and turn off from button 4 if network terminations are correct. Only once the full network is test correct can commissioning begin. Advanced functions can be commissioned via Envision software. If commissioning is required, contact your local distributor for details.

Power Sources – This device should only be operated from the type of supply specified on the front panel. This device *must* be earthed.

Output Circuits – The load on a circuit should not exceed the specified capacity of 5A, or 5A total for each group of three protected circuits. Loads should be calculated to ensure that the overall maximum capacity of 16A is not exceeded. De-rating factors should be applied where relevant to provision for inrush currents associated with certain lighting loads, i.e., electronic ballasts. Refer to Controller Loading for further details.

Load Type – Default settings are for load control outputs to be DSI. Check to see what type of HF Fluorescent Ballasts are in the luminaries. Do not terminate the control lines to any DALI or DSI loads until the relevant channel has been programmed appropriately. When connecting 1-10V load control lines, pay attention that the correct polarity is maintained.

Megger Testing – Do not megger test any circuitry connected to the dimming system, as damage to the electronics may result.

Mounting Location – Ceiling placement is the preferred option as long the unit is mounted securely. Be it via drop rod, wall slab, or cable tray mount. Avoid direct contact on ceiling tiles.

Mains Cable – Structured/Modular wiring cable in either 5 pole or 6 pole format. The unit comes in either “C” format for CMS cable systems or “W” format being Wieland systems.

Mains Isolation – Note that most structured wiring solutions for upstream supply circuitry which include both network and power (5 pole) only provide functional isolation between the data and mains circuits. Note the floor network in this case must be considered at mains potential not SELV and all floor network wiring should include the appropriate provision for prevention of access to live parts. The main DyNet floor network port on the DBC905 is optically isolated from the dry contact inputs and local DyNet ports for this reason.

Network Spur Termination – Care needs to be taken when terminating network spur wiring at floor bridges (area controllers) to prevent access to parts and wiring considered potentially live. Under these circumstances only DBC905 controllers should be connected to the floor network as they incorporate an isolated port.

User Interfaces - Under no circumstances should a standard user interface be connected directly to the floor network as this may permit user access to potentially live parts. All user interfaces such as sensors and panels should be connected to the local port on the DBC905 which provides SELV isolation from mains and the floor network. Where it is required to connect user interfaces to a floor network of this type, a bridge should be always used to provide effective isolation.

features

- **Supply**
230V 50/60Hz single phase & neutral with protection rated up to 20A. Total maximum controller load 16A.
- **Structured Wiring Outputs**
9 x 6 pole structured wiring connectors providing switched active, neutral, earth, maintained active, and dimming control output connections. Each switched active is 5A nominal rated and controlled via a high specification relay. Each output supports 1-10V, DSI, DALI broadcast or DALI Addressed protocols for use with dimmable electronic ballasts and transformers.
- **Output Relay Capacity**
1 x maintained NC switched output at 5A resistive.
9 x Switched outputs capable of supplying 5A resistive, 2A electronic ballast, maximum 100A surge. Max load per block of 3 channels is 5A.
Protection
3 x 6.3A replaceable HRC fuse links protecting three outputs each.
Fuse 1 feeds Ch 1, Ch 2 & Ch 3 (total load 5A resistive)
Fuse 2 feeds Ch 4, Ch 5 & Ch 6 (total load 5A resistive)
Fuse 3 feeds Ch 7, Ch 8 & Ch 9 & Maintained switched output (total load 5A resistive).
- **Control Output Capacity**
9 x Control Outputs, each selectable to;
- DALI broadcast: max 5 DALI loads per ch.
- DALI addressed: max 5 DALI loads per ch.
- 1-10V: max 10mA Sink or Source per ch.
- DSI: max 5 DSI loads per ch.
- **Power-up In Rush Circuit Control**
Incorporated control feature that staggers operation of power relays by 100mS to minimise potential inrush currents.
- **Many Control Options**
The DBC905 is fully scalable and can be readily integrated with other Dynalite products. Control of this device can be from a combination of methods, eg. RJ12 DyNet control ports, retractive switch connectors, relay contacts, push button wall stations, infra red receivers and timeclocks. Easy high-level interface to other popular AV control systems and Building Management Systems (BMS) via the DyNet control network is also available.
- **Simple Installation**
Placed in the ceiling space either via drop rod, wall, slab or cable tray mounting. The device incorporates structured wiring connectors throughout, which enables the unit to be readily connected or disconnected without use of tools.

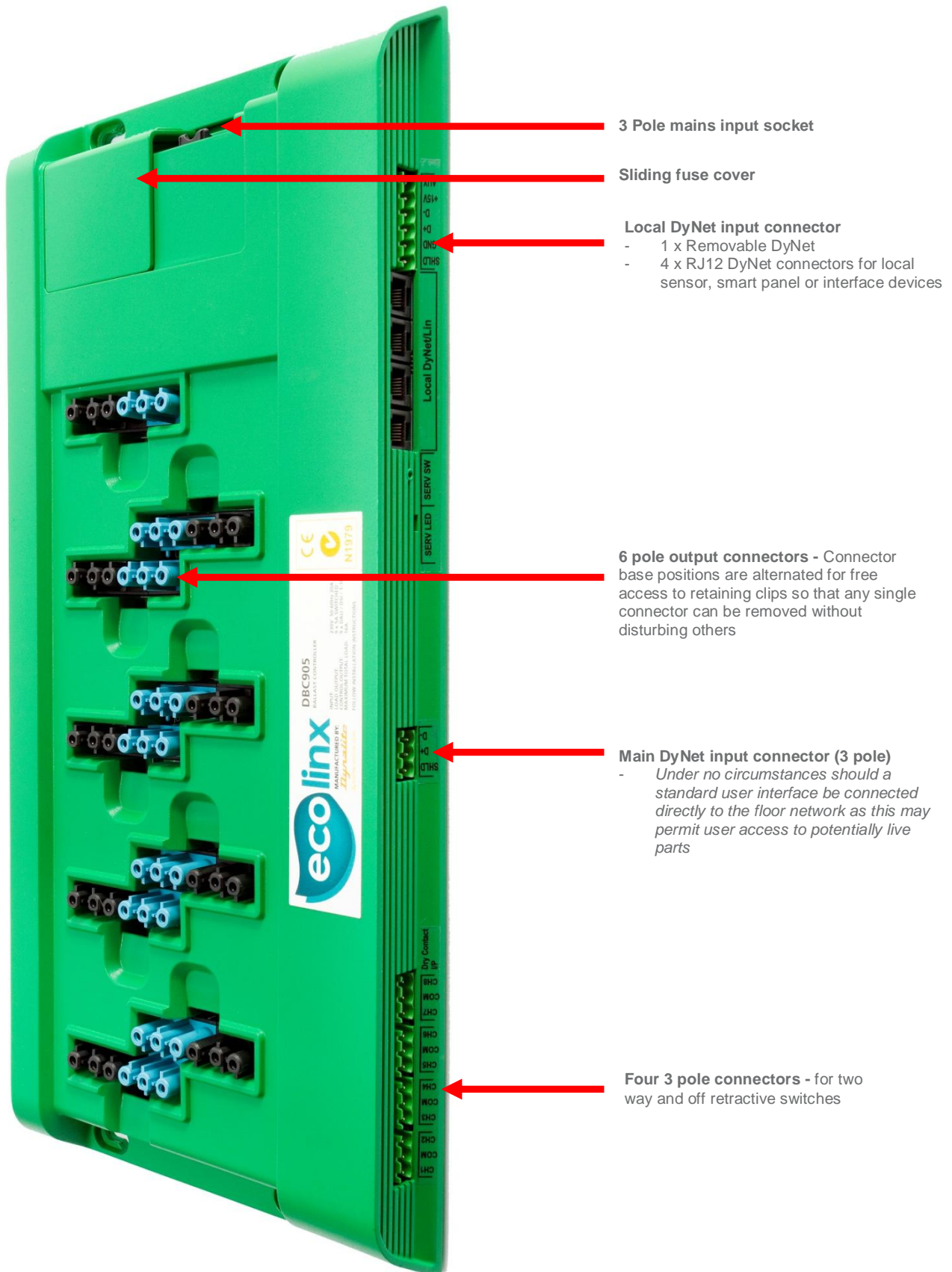

3 Pole mains input socket

Sliding fuse cover

Local DyNet input connector
 - 1 x Removable DyNet
 - 4 x RJ12 DyNet connectors for local sensor, smart panel or interface devices

6 pole output connectors - Connector base positions are alternated for free access to retaining clips so that any single connector can be removed without disturbing others

Main DyNet input connector (3 pole)
 - *Under no circumstances should a standard user interface be connected directly to the floor network as this may permit user access to potentially live parts*

Four 3 pole connectors - for two way and off retractive switches

installation & wiring

Controller Loading

The DBC905 controller is suitable for connection to a supply rated and protected up to 20A. This enables more than one controller to be connected to a single lighting circuit. Care should still be exercised when considering circuit loading as lighting fixtures which incorporate electronic ballasts tend to draw high power-up inrush currents. Nuisance tripping of circuit breakers can result if loading is not carefully considered. The DBC905 incorporates a control feature that staggers operation of the power relays by 100mS to minimise potential inrush currents. For a typical C characteristic thermal magnetic circuit breaker, it is recommended that a de-rating factor of 0.6 be applied when calculating total circuit loading. For example, a typical 2 x 28W T5 light fixture operating on 230V nominal supply will draw approximately 0.3A. When fed from a 16A protected lighting circuit, this permits a recommended total load of approximately 32 lighting fixtures (16 x 0.6 / 0.3). If using the DBC905 with a single fixture connected to each output it would be possible to connect 4 controllers to one 16A lighting circuit as illustrated below.

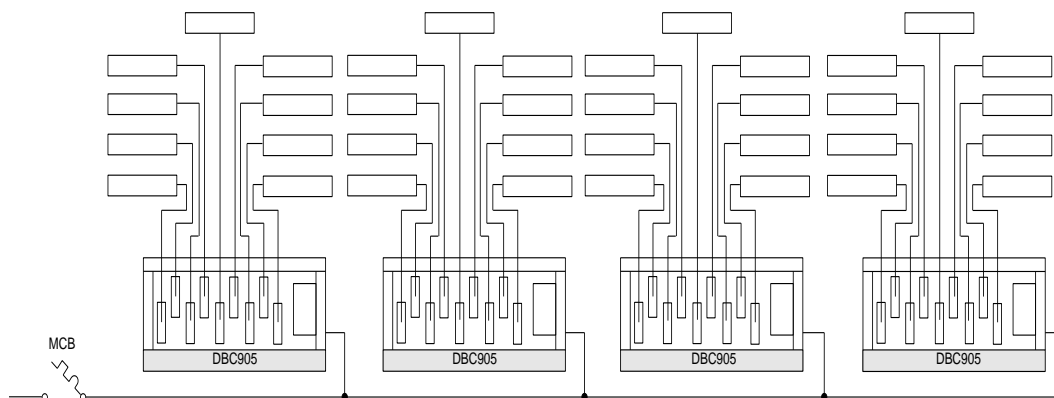

The DBC905 can also support multiple light fixtures connected to a single output to deliver greater economy if required. Care again should be exercised with this approach to not exceed output capacity limitations. It should be noted that each group of three output channels (CH1,2,3, CH4,5,6, CH7,8,9) is protected by a replaceable slow blow 6.3A HRC fuse.

Example DALI Ballast Limit Calculations

- DALI ballasts with 15A startup inrush: 5 per channel. In this example the number of ballasts is limited by the control output limit of 5 DALI loads.
- DALI ballasts with 40A startup inrush: 2 per channel. In this example the number of ballasts is limited by the switched circuit rating of 100A surge.

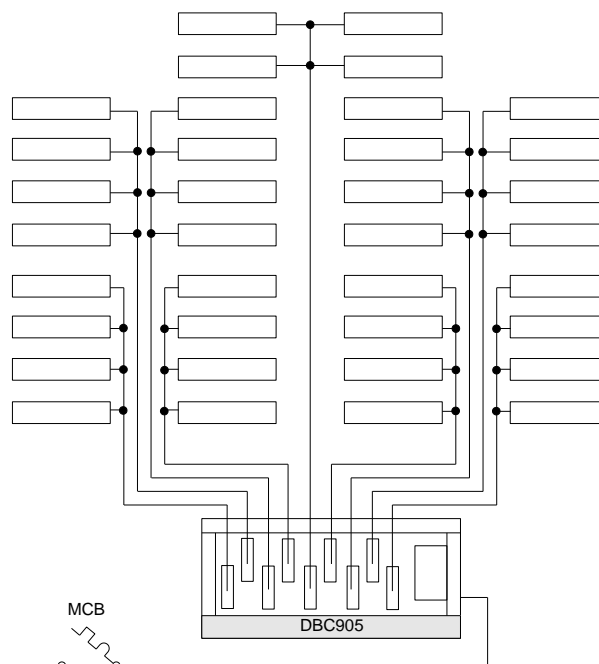

Fixing the Device

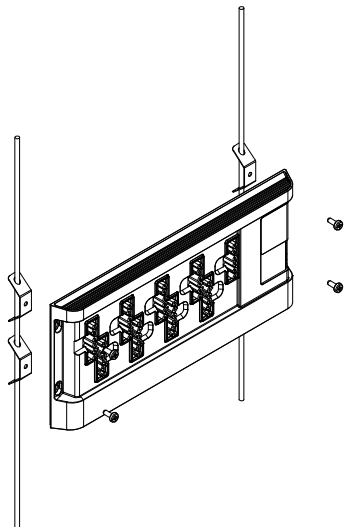

Wiring Terminations



Supply and Output Connections

DBC905W Output Connector Pole Assignments

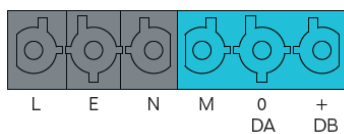

DBC905W pole mains input socket



DBC905C Output Connector Pole Assignments

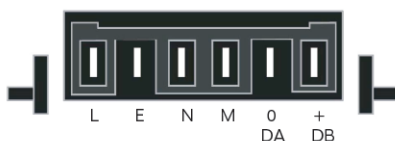

DBC905C pole mains input socket



Select a Suitable Location

This device is designed for indoor use only. If installing in an external location, the DBC905 must be housed in a suitable enclosure. Choose a dry location that will be accessible after the installation is complete. To prevent dust or particle penetration the controller should be mounted so that connector apertures do not face directly upwards. Recommended mounting methods include surface wall, slab, cable tray or “drop rod” suspension.

Fixing the Device

The controller has two keyhole slots located at each end of the housing, which can accommodate fixing screws up to 6mm diameter. The preferred method of mounting is shown below using “drop rods” with appropriate fastening clips.

Wiring Terminations

Removable connectors are utilised for all wiring terminations to simplify maintenance, installation and replacement. Note that controllers are supplied without connectors. Please order connectors separately as required.

Supply and Output Connections

The DBC905 is available in two configurations supporting popular structured wiring brands; CMS Electracom / Modular Wiring tag series and Wieland GST18 series. Units are designated by item code as DBC905C (CMS) OR DBC905W (Wieland). Both cable vendors offer a range of wiring solutions and accessories for both the upstream supply and downstream load wiring. The upstream supply and downstream load wiring. The upstream wiring solutions combine both the mains supply and floor network circuits into one wiring assembly, which can dramatically reduce installation time. Please refer to respective vendor for guidelines on connector and cable assembly selection.

Energising the Device

If it is necessary to energise load circuits before any control cables are connected, it is acceptable to power the device immediately, as the default factory programming is to have all channels set to 100% output. If there is no output on any or all channels, see the troubleshooting section (page 12). This device should be de-energised before terminating the control and data cables.

installation & wiring

Local RJ12 Network Connections

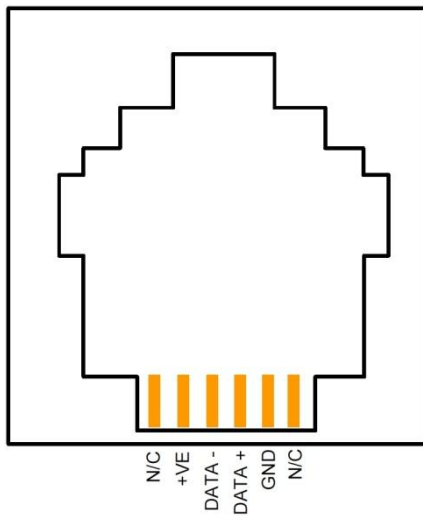

Local Screw Terminal Network Connections

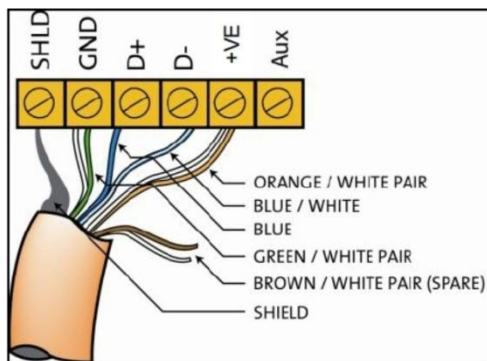

Dry Contact Switch Input Connections



Local RJ12 Network Connections

There are four RJ12 DyNet connections which provide full DyNet connectivity suitable for supporting other network devices such as User Panels and sensors. Note – Recommended total devices per RJ12 socket is 5, up to a maximum of 10. Maximum total devices across all sockets is 20. Please only use Dynalite approved DyNet Flat Shielded cable (DYNET-SFLAT6-CABLE).

Local Screw Terminal Network Connections

There is also one removable 6 pole connector socket RS485 local DyNet Serial Port for screw termination of STPCat5E cable. Refer to page 9 for details on compatible connectors. The recommended cable for connections to this serial port is screened, stranded RS485 data cable with three twisted pairs. Recommended cable types include:

Belden:	9503
Dynalite:	DYNET-STP-CABLE
Garland:	MCP3S
Hartland:	HCK603
M&M Cable:	B2003CS
M&M Cable:	B9503CS
Multicables:	AWM E120236 2092 20
RS Components:	368-687

Recommended Cable Colour Coding

- Green/White pair:* Paralleled for GND
- Orange/White pair:* Paralleled for +VE
- Blue/White pair:* Blue for DATA+
- White for DATA-
- Brown/White pair:* Spare or for Join

The colour-coding scheme used is not critical, as long as the same scheme is used throughout the installation. One pair is paralleled for GND, one pair paralleled for +VE and one pair used for DATA+ and DATA -.

Dry Contact Switch Input Connections

The DBC905 incorporates 4 x voltage free single pole double throw (SPDT) switch inputs, momentary or latch action with four x 3 pole removable terminal sockets for connection of two way on and off retractable switches. Refer to page 9 for details on compatible connectors.

Network Connections

Serial ports are used to interconnect other dimmers, smart control panels, sensors and AV controllers.

The DBC905 circuit design incorporates multiple layers of isolation to deliver robust fault tolerance and uncompromising safety. It should be noted that most structured wiring solutions for upstream supply circuitry which include both network and power (i.e. 5 pole systems) only provide functional isolation between the data and mains circuits. Where such wiring systems are used, the floor network must be considered at mains potential not SELV and all floor network wiring should include the appropriate provision for prevention of access to live parts. The main floor network port on the DBC905 is isolated for this reason. The isolation will tolerate a fault which raises the floor network to mains potential. Note that this does not include mains potential applied across D+ and D- which would of course result in destruction of circuit components. Isolation is also separately provided to the local DyNet ports and switch inputs. This ensures that all switch inputs and local network circuits are SELV and prevents propagation of faults from these circuits across the floor network.

Where an upstream structured wiring solution is used, care should be made when terminating network spur wiring at floor bridges (area controllers), to again prevent access to parts and wiring considered potentially live. In this case only DBC905 controllers should be connected to the floor network as they incorporate the isolated port. Under no circumstances should a standard user interface be connected directly to the floor network as this may permit user access to potentially live parts. All user interfaces such as sensors and panels should be connected to the local network ports on the DBC905 which provide SELV isolation from mains and the floor network. Where it is necessary to connect user interfaces to a floor network of this type, a bridge should be always used to provide effective isolation.

Floor Network Serial Connection

The main DyNet floor network port incorporates a 3 pole removable terminal socket which provides for data pair and shielded connection only suited to 5 pole structured wiring systems with integrated mains power circuits. Refer to page 9 for details on compatible connector

Hardware Controls

AUX Input - This is a dry contact interface that is active low. The dry contact is connected between the AUX and GND terminals on the DyNet connector strip. The function of the AUX input is programmable. Ensure that the cable length between the dry contact and terminal strip is no longer than 2 metres.

Service LED - The Service LED has 3 signalling modes, which are useful for troubleshooting:

Blinking slowly (1Hz) = Normal Operation

Blinking fast (4Hz) = Network Activity Detected

On = Fault

Service Switch - The Service Switch has three functions:

1 push = Transmit Network ID

3 pushes = All Channels 100% (Initialise DALI ballasts)

Push & hold for 4 sec = Reboot

network & input removable terminal connectors

note: Controllers are supplied without connectors. Please order connectors separately as required.

<u>Local DyNet Terminal</u>	<u>Main Floor Network Port and Switch Input Terminals</u>
<p>6 pole removable terminal socket Compatible screw terminal connectors:</p> <p>Wieland: Standard: Wiecon 8113 Wieland Order No: 25.320.3653.0 (box of 50) Strain relieved: Wiecon 8113 Wieland Order No: 25.320.8653.0 (box of 50)</p> <p>Phoenix Contact: Standard: Combicon MSTB 2.5/6-ST Phoenix Order No: 1754520 (box of 50) Strain relieved: MSTB 2.5/6-STZ-5.08 Phoenix Order No: 1776126 (box of 50)</p> <p>PTR: Standard: PTR Order No: AK950/6-5-0-GREEN Strain relieved: PTR Order No: AK950/6L-5.0-GREEN</p> <p>Dynalite Item Codes: Standard: 625-375 Strain relived: 625-372</p>	<p>3 pole removable terminal sockets Compatible screw terminal connectors:</p> <p>Wieland: Standard: Type: Wiecon 8113 Wieland Order No: 25.320.3353.0 (box of 100) Strain relieved: Wiecon 8113 Wieland Order No: 25.320.8353.0 (Box of 100)</p> <p>Phoenix Contact: Standard: Combicon MSTB 2.5/3-ST Phoenix Order No: 1754465 (box of 50) Strain relieved: MSTB 2.5/3-STZ-5.08 Phoenix Order No:1776168 (box of 50)</p> <p>PTR: Standard: PTR Order No: AK950/3-5.0-GREEN Strain relieved: PTR Order No: AK950/3L-5.0-GREEN</p> <p>Dynalite Item Codes: Standard: 625-379 Strain Relived: 625-373</p>

6 Pole removable terminal connectors



3 Pole removable terminal connectors



typical equipment layout

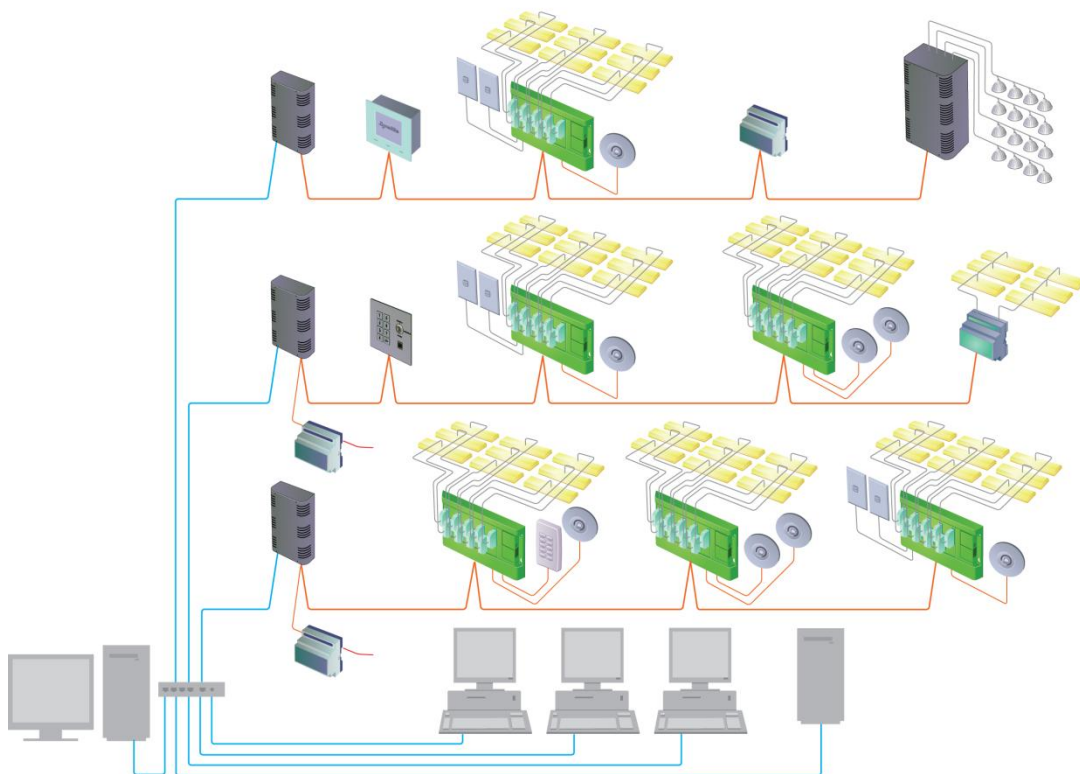
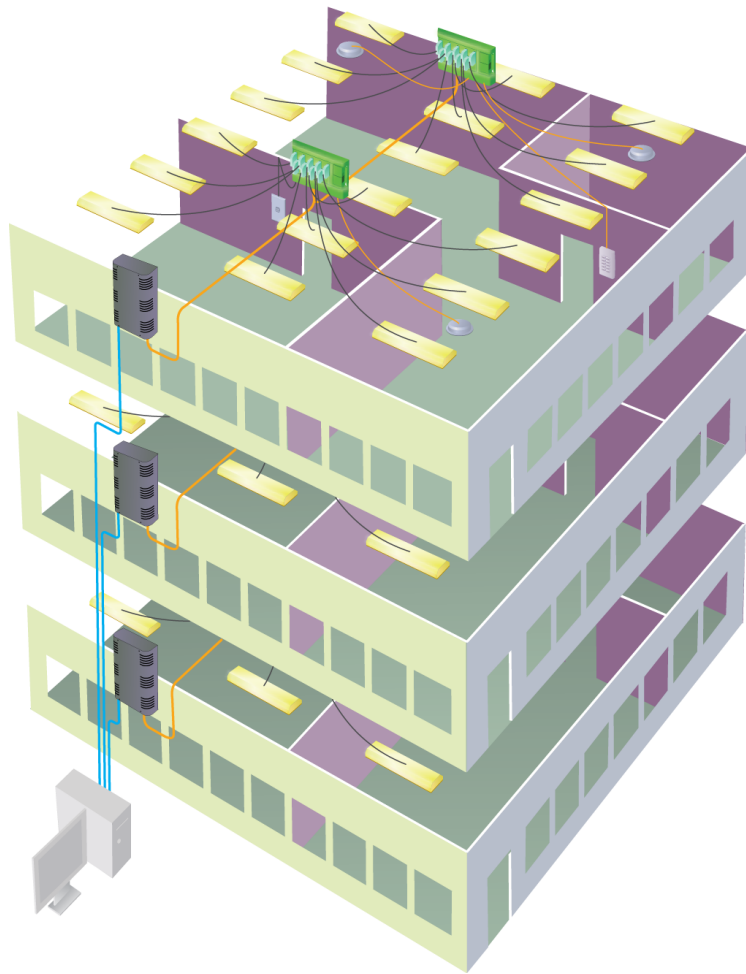

notes

Check the following list. If you are still unable to rectify the situation, contact your nearest Dynalite office. A complete list of distributors worldwide can be found on the Internet at: www.philips.com/dynalite
Please ensure that you have completed the following prior to calling our technical support department.

- Check all symptoms in the Troubleshooting list
- Check for any deviations between the installation and the installation instructions
- Make a list of the model numbers of all devices used in the system

SYMPTOM	PROBABLE CAUSE	ACTION
Dimmer does not operate at all. No Service LED activity. Power supply indicator LED on PCB not lit.	Incorrect connection of mains supply or no power available.	Check power supply to dimmer. Check Line and Neutral input connections.
Power supply indicator LED lit, but no Service LED activity.	Supply voltage too low, short circuit on network. Control PCB faulty.	Check supply voltage is at least 75% of rated voltage. Check 5V & 12V terminal voltages, 5V supply must be present. Disconnect network bus and restore power. Replace control PCB.
Dimmer will not respond to control panel push buttons.	Control panel incorrectly wired. Incorrect configuration.	Check operation of LEDs on control panel. Push button on panel and study response of service LED.
Dimmer operates properly but circuit breakers keep tripping.	Instant tripping: - short circuit on load. Delayed tripping: - Dimmer overloaded.	Check load wiring for short circuits. Verify dimmer loading with current tester (don't forget to de-rate for low power-factor loads and transformer losses). Check that the breaker terminals are tight.
Fluorescent lights won't dim.	Wrong type of ballast or ballast incorrectly wired. Control cable from dimmer to ballasts not installed.	Check ballast type. Check actual wiring against ballast manufacturer's diagram. Check 1-10V/DSI/DALI cable and settings.

specification

Supply:	230V 50/60Hz single phase & neutral at 16A
Outputs:	1x Maintained NC switched output at 5A resistive 9x Switched outputs capable of supplying: - 5A resistive, 2A electronic ballast, maximum 100A surge - max load per block of 3 channels is 5A
Control Outputs:	9 x Control Outputs, each selectable to: - DALI broadcast: max 5 DALI loads per ch. - DALI addressed: max 5 DALI loads per ch. - 1-10V: max 10mA Sink or Source per ch. - DSI: max 5 DSI loads per ch.
Protection:	3 x 6.3A replaceable HRC fuse links Fuse 1 feeds Ch 1, Ch 2 & Ch 3 (total load 5A resistive) Fuse 2 feeds Ch 4, Ch 5 & Ch 6 (total load 5A resistive) Fuse 3 feeds Ch 7, Ch 8 & Ch 9 & Maintained switched output (total load 5A resistive)
Control Ports:	Local DyNet RS485 1 x RS485 DyNet Serial Port 1 x AUX programmable dry contact input 4 x RJ12 DyNet connections for multifunction sensors (motion, PE illuminance, and IR receive), user panels and other interface devices. Recommended total devices per RJ12 socket - 5, up to max. of 10. Max. total devices for all sockets - 20 Floor DyNet RS485 1 x RS485 DyNet Serial Port (functionally isolated from mains)
Control Inputs:	4 x voltage free single pole double throw (SPDT) switch inputs, momentary or latch action 1 x programmable dry contact AUX input
DyNet DC Supply +VA:	400mA
Preset Scenes:	170
Diagnostic Functions:	Device online/offline status Circuit breaker trip monitoring (optional) Circuit run time tracking (optional) The availability of some diagnostics is dependent on the ballast type.
Compliance:	CE, C-Tick
Operating Environment:	0° to 50°C ambient temperature, 0% to 95% RH non condensing
Construction:	Moulded ABS
Dimensions:	H 189mm x W 416mm x D 35mm
Weight:	Packed weight 2kg